

ELETTROVENTILATORI ASSIALI BRUSHED

VA33-BP93/LL-65A

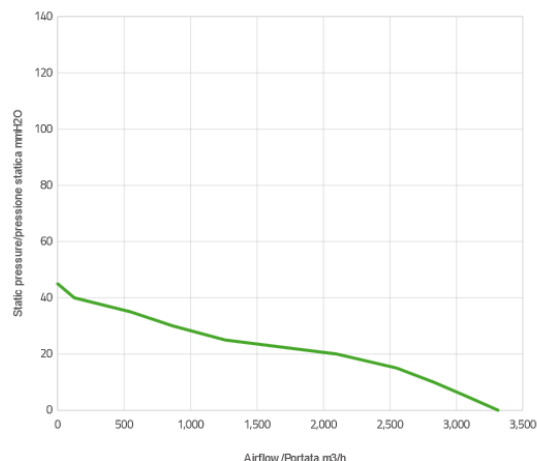

Curva Prestazionale



Dettaglio prestazioni

Pressione statica	Flusso d'aria	Corrente in ingresso	Flusso d'aria	Pressione statica
mm H ₂ O	m ³ /h	A	CFM	in H ₂ O
0	3313	11,1	1955	0
5,0	3074	11,6	1814	0,2
10,0	2828	12,0	1669	0,4
15,0	2551	12,4	1505	0,6
20,0	2099	12,4	1238	0,8
25,0	1260	11,9	743	1,0

This is a not-controlled copy electronically created from the web site www.spalautomotive.com. The information contained herein is subject to change without notice. This catalogue/web site does not imply that any such parts are available for supply. The publisher and any party associated with the production of this catalogue/web site do not accept any responsibility or liability whatsoever (to the extent permitted by law) for any inaccuracy, error, misinformation or misleading statements, whether negligently caused or otherwise, contained in this publication. This publication is protected by copyright and may not be reproduced or copied (using any method of reproduction or copying), sold, transmitted, circulated or otherwise forwarded to third parties, in whole or part, without prior written consent of the author.

Pressione statica	Flusso d'aria	Corrente in ingresso	Flusso d'aria	Pressione statica
30,0	866	12,0	511	1,2
35,0	549	12,1	324	1,4
40,0	125	12,7	74	1,6
45,0	0	13,1	0	1,8

This is a not-controlled copy electronically created from the web site www.spalautomotive.com. The information contained herein is subject to change without notice. This catalogue/web site does not imply that any such parts are available for supply. The publisher and any party associated with the production of this catalogue/web site do not accept any responsibility or liability whatsoever (to the extent permitted by law) for any inaccuracy, error, misinformation or misleading statements, whether negligently caused or otherwise, contained in this publication. This publication is protected by copyright and may not be reproduced or copied (using any method of reproduction or copying), sold, transmitted, circulated or otherwise forwarded to third parties, in whole or part, without prior written consent of the author.

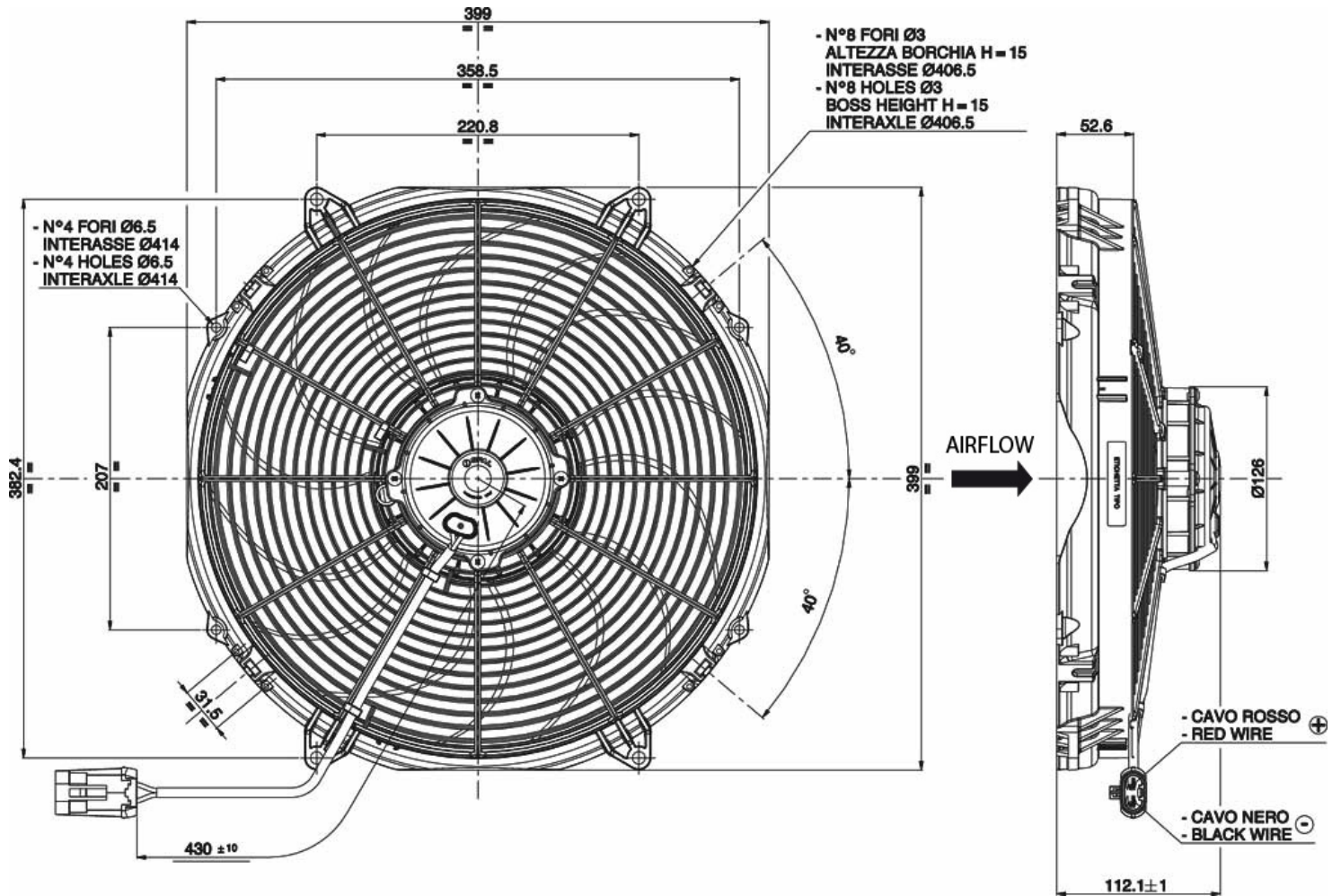

This is a not-controlled copy electronically created from the web site www.spalautomotive.com. The information contained herein is subject to change without notice. This catalogue/web site does not imply that any such parts are available for supply. The publisher and any party associated with the production of this catalogue/web site do not accept any responsibility or liability whatsoever (to the extent permitted by law) for any inaccuracy, error, misinformation or misleading statements, whether negligently caused or otherwise, contained in this publication. This publication is protected by copyright and may not be reproduced or copied (using any method of reproduction or copying), sold, transmitted, circulated or otherwise forwarded to third parties, in whole or part, without prior written consent of the author.